



# BEVERAGE-AIR

Project: _____	AIA#
Item: _____	
Location: _____	SIS#
Approved: _____	

**SPED27HC SANDWICH PREP: STANDARD TOP**

## FOOD PREPARATION TABLES

SPED27HC Sandwich Prep Table With Drawers  
Hydrocarbon Series

MODEL:  
SPED27HC-B



**5 Year Parts/Labor Warranty Available**

**7 Year Compressor Warranty**

### CABINET CONSTRUCTION

- Stainless steel front, sides, top, drawers, and grille (galvanized steel back & bottom)
- Interior liner is made of corrosion resistant aluminum
- Removable hoods made of matching stainless steel
- Full electronic control
- Airflow assures that product in open containers is kept below 41°F and above freezing
- Eight (8) 1/6 4" deep pans constructed of polycarbonate plastic
- Pans furnished are 4" deep constructed of polycarbonate plastic
- Snap-in magnetic gaskets for positive drawer seal
- Painted aluminum drawer handles
- 10" Wide cutting board constructed of white polyethylene plastic
- Cutting board removable for cleaning
- Stainless steel drawer frames supported on telescoping drawer slides
- Drawer slides include locking mechanism that prevents drawers from being inadvertently pulled off cabinet
- 6" Casters, with (2) brakes standard

### OPTIONS & ACCESSORIES

- 3 Year parts/labor standard, additional 2 year warranty available
- Stainless steel back
- Stainless steel interior
- Clear lid
- Overshelves (single or double)
- Crumb catcher
- Richlite cutting board
- Night cover
- Pan supports
- Pan support crossbar
- Pan configuration
- 6" Legs or 3" casters
- Low profile casters
- Remote option\* (see note on back page)

### REFRIGERATION SYSTEM

- Uses environmentally friendly, energy efficient R290 refrigerant, and meets all regulatory requirements for CARB, SNAP, DOE & more
- Adaptive defrost
- Epoxy coated evaporator coil
- Enhanced airflow maintains temperatures between 36° - 38°F



Please verify qualifying units by visiting:  
[www.energystar.gov/cfs](http://www.energystar.gov/cfs)



3779 Champion Blvd., Winston-Salem, NC 27105  
1-888-845-9800 Fax: 1-336-245-6453  
Beverage-Air.com Sales@bevair.com



# BEVERAGE-AIR

## Food Preparation Table with Drawers: Standard Top Model: SPED27HC-B

MODEL	SPED27HC-B
<b>EXTERNAL DIMENSIONAL DATA</b>	
Width Overall	27"
Depth Overall	32"
Height Overall with Casters	45 <sup>3</sup> / <sub>8</sub> "
No. of Drawers	2
Depth with Drawers Open 90°	47 <sup>3</sup> / <sub>4</sub> "
Drawers Openings	22 <sup>5</sup> / <sub>8</sub> " x 11 <sup>3</sup> / <sub>8</sub> " 22 <sup>5</sup> / <sub>8</sub> " x 7 <sup>1</sup> / <sub>2</sub> "
Width, Cutting Board	10"
<b>INTERNAL DIMENSIONAL DATA</b>	
NET Capacity (cubic ft.)	6.91
Internal Width Overall (in)	23"
Internal Depth Overall (in)	15 <sup>1</sup> / <sub>2</sub> "
Internal Height Overall (in)	23"
No. of Pans	8
<b>ELECTRICAL DATA</b>	
Full Load Amperes	2.0
<b>REFRIGERATION DATA</b>	
Horsepower	1/10
Capacity (BTU/Hr)	1110
Heat Rejection (BTU/Hr)	1665
Charge (lbs/grams)	0.1102/50
<b>SHIPPING DATA</b>	
Gross Weight - Crated	238 lbs
Height - Crated	46"
Width - Crated	30"
Depth - Crated	32"

\*NOTE: Remote units are field wired and come with 6" legs.  
Refrigerant must be specified at time of order.

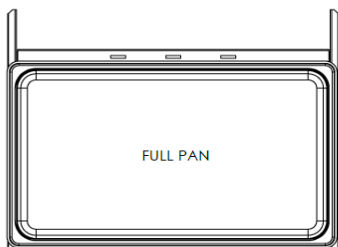

### Model Views

Required Clearance: 3" bottom & 2" rear

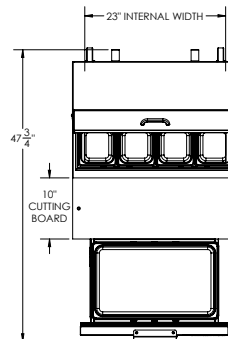

### PLAN VIEW

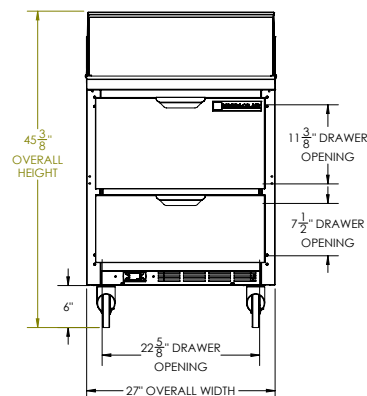

### ELEVATION VIEW

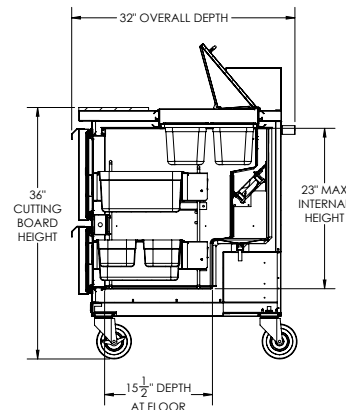

### SIDE VIEW



### ELECTRICAL CONNECTION

115/60/1  
NEMA 5-15P

Unit pre-wired at factory  
and include 8' long cord  
and plug set.